



SynSysCo Floating Scroll Vacuum Pump

SSC

05 | 20 | 50 Series



PO Box 177 | 16241 63.00 Road, Suite A
Montrose, Colorado 81402

970-240-9429

Fax: 970-240-8996
sales@synsysco.com

SSC Characteristics

Introducing the SSC Series compact floating scroll pumps from SynSysCO. Sizes from 5 to 50 Liter/minute, with available ultimate pressure as low as 75 mTorr.

- Patented Floating Scroll Technology
- Oil Free Operation
- No tip seal or PTFE dust
- No tip seal or diaphragm needing replacement
- High performance
- Compact size
- Long product life
- High level of gas tightness
- Very quiet and low vibration
- Can operate in any installed position

SYN·SYS·CO

SSC 05 Series



Dimensions: (mm)

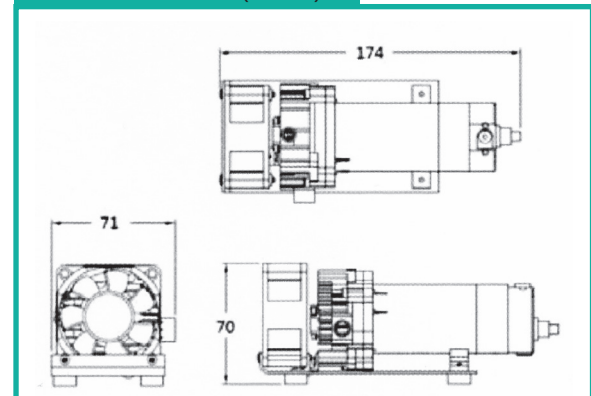

Pumping Speed:

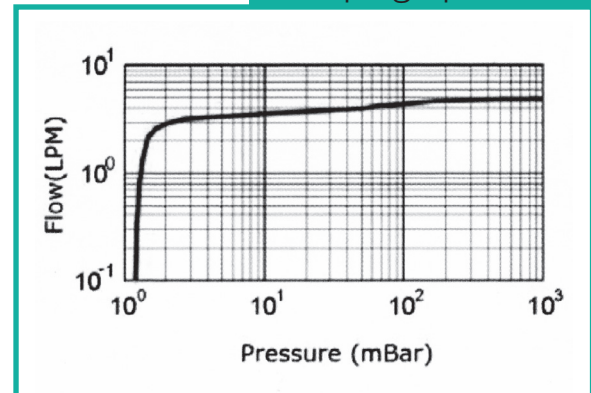

Dimensions: (mm)

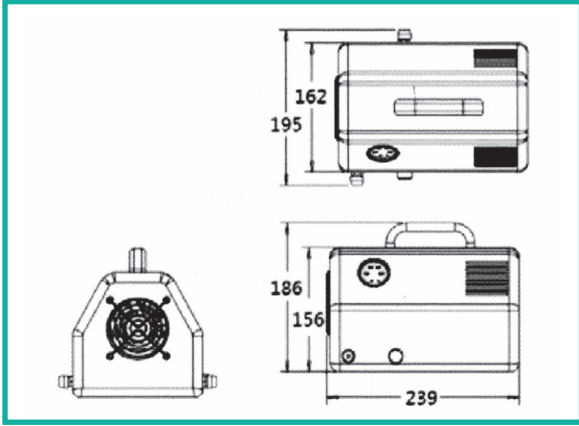

SSC 20 Series



Pumping Speed:

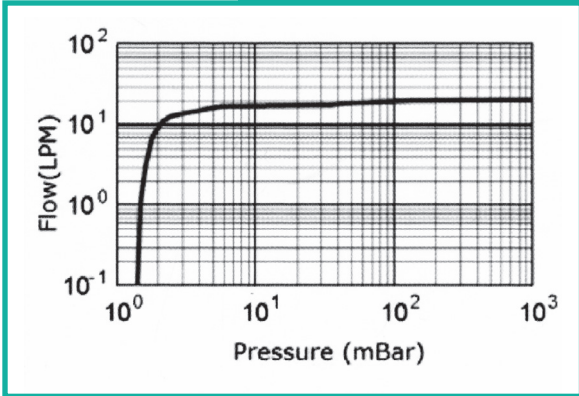

SSC 50 Series

Dimensions: (mm)

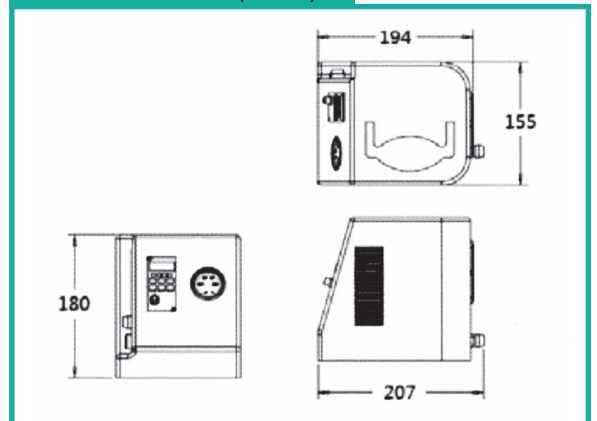

Pumping Speed:

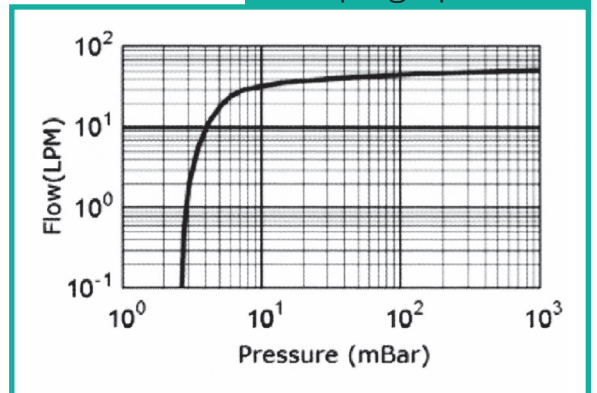

Synergy Systems Corporation, Inc.

PO Box 177 | 16241 63.00 Road, Suite A | Montrose, Colorado 81402

970-240-9429 | Fax: 970-240-8996 | sales@synsysco.com

Technical Data

	SSC05-750 SSC05-075	SSC20-750 SSC20-075	SSC50-750 SSC50-075
Displacement	5L/min	20L/min	50L/min
Ultimate pressure	750 mTorr 75 mTorr	750 mTorr 75 mTorr	750 mTorr 75 mTorr
Power consumption, Max.	15 ± 2 W	70 ± 2 W	95 ± 3 W
Motor Type	Brushless DC Motor		
Voltage	12VDC Or 110-220 VAC	24 VDC Or 110-220 VAC	
Noise Level	≤45 dBA	≤60 dBA	
Weight (w/o case)	0.5 kg / 1.1 lb	1.7 kg / 3.7 lb	1.0 kg / 2.2 lb
Dimensions (w/o case) LxWxH	142x71x58 mm 5.59x2.79x2.28 in.	203x132x132 mm 7.99x5.20x5.20 in	124x90x87 mm 4.88x3.54x3.42 in
Dimensions (w/ case) LxWxH	174x71x70 mm 6.85x2.79x2.76 in	239x195x186 mm 9.41x7.68x7.32 in	207x155x180 mm 8.15x6.10x7.09 in
Inlet Connection	NW16		
Outlet Connection	NW16		
Ambient Temperature	-40°F to 140°F -40°C to 60°C		
Options upon Request	Variable Speed Control	Variable Speed Control No Case	Variable Speed Control Controller No Case



www.SynSysCo.com